



ISN T8 IMPEDANCE STABILIZATION NETWORK (ISN) FOR UNSCREENED BALANCED PAIRS



- For use with one, two, three, or four unscreened balanced pairs
- Refers schematic circuit example in CISPR 22/32 Figure D.3/G.3
- Intended for connection to cable category 3 and 5
- 1000BaseT and PoE application
- Changeable pin-arrangements with RJ11 and RJ45

Standards:

- CISPR 16-1-2
- CISPR 22
- CISPR 32
- And others

Impedance stabilization networks (ISN, or with CISPR 16-1-2 called AAN: asymmetric artificial network) are defined for measuring of conducted common mode disturbances at information technology equipment (ITE) as required in CISPR 22 and CISPR 32. The ISN is placed between the equipment under test (EUT) and auxiliary equipment (AE) or load which are necessary for the operation of the EUT. The ISN establishes the common-mode termination impedance for the EUT's telecommunications port during measurement and emulates the unsymmetrical contribution (longitudinal conversion loss, LCL) of the connected line. Different ISNs are available in relation to the line category, line numbers and pin-arrangement.

The ISN T8 is designed for measurements on up to four unscreened single balanced pairs and consists of one basic network (ISN T800) with D sub 25 connectors and special adapter sets. A set of adapters consists of two pieces of LCL adapters to arrange the lines and realize longitudinal conversion loss (LCL)- requirements for the EUT-side in relation to the use cable category (cat. 3, cat. 5) and one piece of connection adapter arranges the lines for the AE-side. Teseq offers two different adapter sets – ADS T800 and ADS T8x0. ADS T800 gives the connection to RJ45 sockets with pin-arrangements of EIA/TIA T568A respectively T568B. The adapter set ADS T8x0 offers changeable pin-arrangements via 1 mm banana connectors for each pin combination of RJ11/RJ45.

Technical specifications

Frequency range:	150 kHz to 30 MHz
Line parameters:	1 up to 4 pair(s)
Power rating (EUT and AE port)	
AC max. voltage (line to ground):	63 V
DC max. voltage (line to ground):	100 V
Current max.:	600 mA (line), 1200 mA (pair)
Test voltage:	200 VDC, 2 sec
Common mode impedance (EUT port) 150 kHz to 30 MHz:	150 Ω ±20 Ω
Phase angle (EUT port) 150 kHz to 30 MHz:	0° ±20°
Coupling path (In/Out port/EUT)	
Connection:	BNC 50 Ω
RF voltage:	<15 V
Frequency range:	150 kHz to 30 MHz
Voltage division factor (RF input to EUT port) 150 kHz to 30 MHz:	10 dB ±1 dB
Transmission bandwidth (wanted signal) EUT/AE B3 dB: *	> 100 MHz sin.
LCL (EUT) *)	
Cat. 3 150 kHz to 30 MHz:	55 dB to 39.3 dB ±3 dB
Cat. 5 150 kHz to 2 MHz:	65 dB ±3 dB
Cat. 5 2 MHz to 30 MHz:	65 dB to 49.3 dB +4.5/-3 dB
Decoupling of common mode disturbances (EUT/AE)	
150 kHz to 1.5 MHz/30 MHz:	≥35 dB to ≥55 dB/≥55 dB
Crosstalk (PSELFEXT) (EUT/AE) 1 MHz to 100 MHz:	≥61 dB to ≥21 dB

*) all balanced parameters are in relation to a symmetrical load of 100 Ω

ISN T8

IMPEDANCE STABILIZATION NETWORK (ISN) FOR UNSCREENED BALANCED PAIRS

Mechanical specifications

Dimensions in mm (W x H x D) (basic network):	105 x 65 x 110
Dimensions in mm (W x H x D) (basic network with adaptors):	105 x 65 x 190
Dimensions in mm (W x H x D) (storage case):	400 x 300 x 110
Weight:	approx. 550 g
Weight (storage case with ISN):	approx. 1800 g

Top view of ISN T8 with basic network and adapter sets

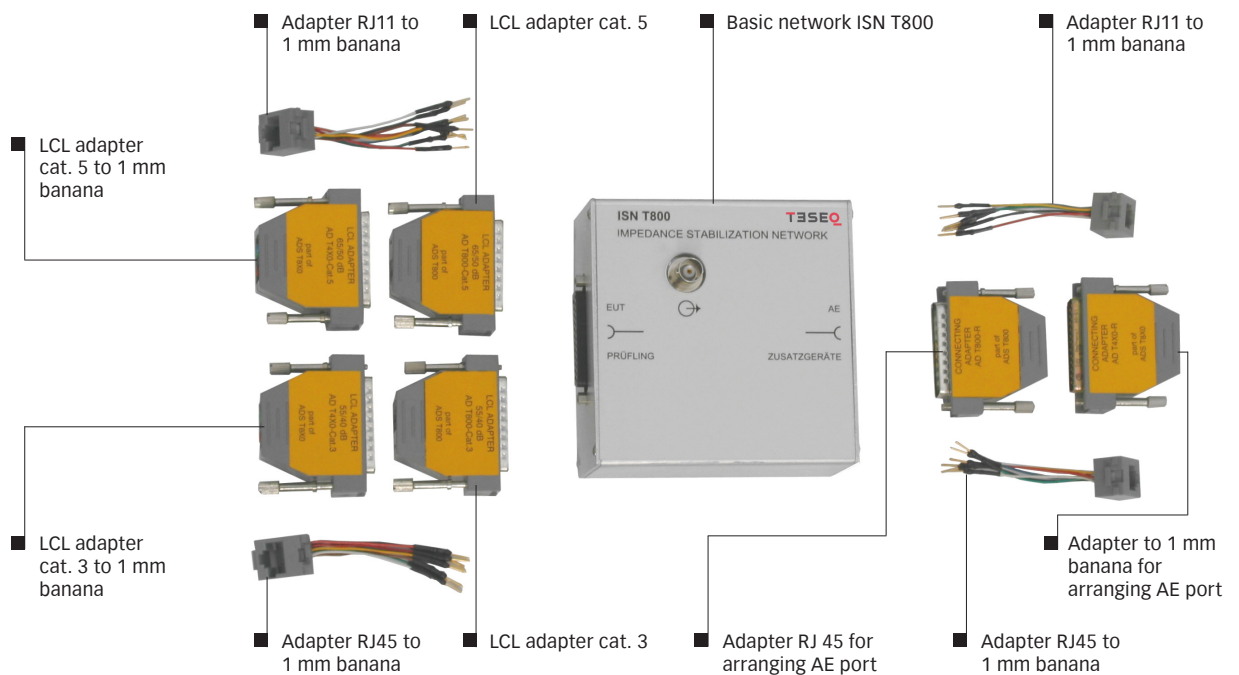

ISN T8 IMPEDANCE STABILIZATION NETWORK (ISN) FOR UNSCREENED BALANCED PAIRS



ISN T8 in storage case

Application

Pin-arrangement for EIA/TIA T568B		Pair 1/ Pin 4,5	Pair 2/ Pin 1,2	Pair 3/ Pin 3,6	Pair 4/ Pin 7,8
Token ring, ISDN basic rate access/S0	RJ45	X		X	
ISDN primary rate access (2Mbps)	RJ45	X	X		
10BaseT, 100BaseTX	RJ45		X	X	
100BaseT4, 100Base VG-AnyLan, 1000BaseT	RJ45	X	X	X	X
ATM, FDDI, TP-PMD	RJ45		X		X
Dt. Telekom, UPO, AS400	RJ11	X			
IBM 3270	RJ45		X		

Typical measuring setup

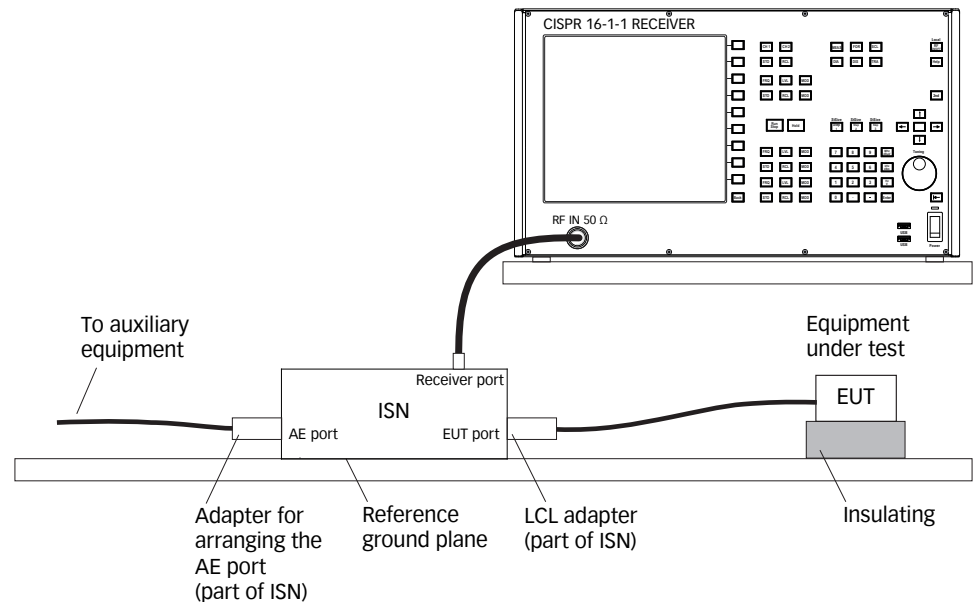

ISN T8 IMPEDANCE STABILIZATION NETWORK (ISN) FOR UNSCREENED BALANCED PAIRS

Model No. and options

Part number	Description
248550	ISN T8 Impedance Stabilization Network (AAN) for CISPR 22/32/16-1-2 basic network for up to eight balanced lines with adapter sets ADS T800 and ADS T8X0, cable cat. 3 and 5 in storage case
97-248550	ISN T8-TC Traceable calibration (ISO17025), order only with device ISN T8 or ISN T8-Cat6
248580	CAS ISN Calibration kit for ISN T8 and ISN T2A, measuring parameters: CM impedance, phase angle, voltage division factor and LCL, traceable calibration and certificate included
257521	A 50-N Termination 50 Ω , N type, male, 1 Watt, 2.5 GHz

AMETEK CTS Europe GmbH
Landsberger Str. 255 · 12623 Berlin · Germany
T +49 30 56 59 88 35 F +49 30 56 59 88 34
customer care.cts@ametek.com
www.ametek-cts.com

© December 2020 Teseq®
Specifications subject to change without notice.
Teseq® is an ISO-registered company. Its products are designed and manufactured under the strict quality and environmental requirements of the ISO 9001. This document has been carefully checked. However, Teseq® does not assume any liability for errors or inaccuracies.

82-248550 E04 December 2020